



"We'll see you right"

THE RIGHT WAY TO BUILD A RETAINING WALL



TOOLS

- ☐ SLEDGE HAMMER
- ☐ SHOVEL
- ☐ SPIRIT LEVEL
- ☐ TAPE MEASURE / SQUARE AND PENCIL
- ☐ SPADE
- ☐ 300MM DIAMETER POST-HOLE BORER
- ☐ CIRCULAR SAW
- ☐ HAMMER
- ☐ PEGS AND STRING LINE

MATERIALS NEEDED

- ☐ SQUARE OR ROUND (150 MM DIAMETER) TIMBER POSTS TREATED AGAINST DECAY TO H5 STANDARD. FOR A 1.2 METRE HIGH WALL THE POSTS ARE 2.4 METRES LONG. YOU WILL NEED ONE FOR EACH 1.3 METRE LENGTH OF WALL PLUS ONE FOR THE END
- ☐ SOME PIECES OF TIMBER FOR TEMPORARY BRACING
- ☐ EX150 MM DIAMETER HALF-ROUND TIMBER RAILS TREATED AGAINST DECAY TO H5 STANDARD. THESE SHOULD BE GAUGED ON THE EDGES TO A UNIFORM WIDTH AND SHOULD BE TWICE AS LONG AS THE POST SPACING I.E. 2.6 METRES LONG. USING EX150 MM WIDE MATERIAL YOU WILL NEED 8 RAILS FOR EVERY 2.6 METRE LENGTH OF WALL
- ☐ 150 MM HOT-DIP GALVANISED NAILS. YOU WILL NEED AT LEAST 3 NAILS FOR EVERY RAIL
- ☐ CONCRETE (17.5 MPA OR 6.1 MIX) - YOU WILL NEED APPROXIMATELY 0.12 CUBIC METRES OF STIFF CONCRETE FOR EACH POST
- ☐ DRAIN COIL - SLOTTED PVC FLEXIBLE DRAINPIPE. YOU WILL NEED SUFFICIENT FOR THE LENGTH OF THE WALL AND TO REACH THE POINT OF DISCHARGE
- ☐ FREE DRAINING METAL BACKFILL - USUALLY CLEAN STONES BETWEEN 20 AND 50 MM DIAMETER. YOU WILL NEED APPROXIMATELY 1/3 CUBIC METRE FOR EVERY METRE LENGTH OF WALL
- ☐ GEOTEXTILE FABRIC. THIS IS A POLYPROPYLENE FABRIC SUITABLE FOR USE IN THE GROUND. YOU WILL NEED SUFFICIENT FOR A 500 MM WIDE STRIP THE LENGTH OF THE WALL
- ☐ TIMBER PRESERVATIVE

DISCLAIMER

Please Note: Whilst the advice and recommendations contained in this brochure have been produced with proper care, they are offered only with the object of assisting those interested in home improvement projects and ITM does not accept responsibility for the advice, recommendations, etc, contained herein.

If you have any queries please contact your local ITM store for further advice.

Note: A Building Consent may be required.



Produced in association with BRANZ.

CHECK OUT OUR OTHER GUIDES IN STORE OR ON THE WEBSITE WWW.ITM.CO.NZ



"We'll see you right"

INTRODUCTION

A well constructed retaining wall can be both a functional asset and an attractive feature of your garden or landscape. It can add valuable additional level space on a sloping section and provide an attractive cover to the face of an earth bank.

There are several types of retaining walls, each suited to particular heights, choice of materials, and the type of ground to be retained. This guide describes a simple-to-build post and rail wall (also known as a cantilever wall) which is versatile and has a natural appearance suitable for most environments.

Even low retaining walls may be subject to high forces acting on them and it is important that the procedures outlined here are followed to ensure the wall is stable.

Low retaining walls, which support not more than 1.5 metres of earth and which do not support any additional loads such as a bank or the weight of vehicles on a driveway, are exempt from the need to obtain a building consent. BRANZ recommends consulting a (structural) engineer for all walls over 1m high.

BUILDING CONSENT

If your wall is higher than 1.5 metres, or it supports a driveway, parking area or the weight of a bank or building above the wall, you should consult an engineer and obtain a building consent.

But even walls which do not require a building consent must comply with the requirements of the New Zealand Building Code and so should be securely and safely constructed.



BEFORE



AFTER

A TIMBER RETAINING WALL

This guide describes a 1.2 metre high cantilevered timber wall which consists of vertical posts embedded in the ground supporting horizontal rails. It includes drainage behind the wall which is an essential part of any retaining wall construction.

SOIL TYPES

The type of soil which is retained and into which the wall is built can have an effect upon the stability of a wall. Suitable soils are granular such as firm gravel (FG), stiff clay (SC) and sand or rock (S/R) (or a mixture of these).

Soils which may be unsuitable include very soft clay (which will squeeze between the fingers when grasped), peat or made-up ground and fill; if your site has one of these types of soil it would be wise to consult an engineer. The type of wall covered by this guide is unsuitable for hard rock because of the difficulty of digging suitable holes.



FG



SC



S/R

NOTE: IF TIMBER TREATMENT IS COPPER AZOLE OR COPPER QUARTERNARY THEN STAINLESS STEEL FIXINGS (NAILS) MUST BE USED.

STEP 1

MEASUREMENTS & MATERIALS

Plan and measure the length and height of the wall keeping as near as possible to the modules of 1.3m post centres and 150mm wide rails and calculate the materials you will need - see "MATERIALS NEEDED".



STEP 2

SET OUT & EXCAVATION

Dig out to a firm level foundation for the wall. Allow for a space of about 300mm minimum behind the back of the wall and the face of the bank for drainage. Put timber pegs in the ground at both ends of the wall and set a string line between the pegs to indicate the back of the wall. Measure for, and place a peg along the string line to mark the position of each vertical post. You should allow 10mm tolerance between the rails so the posts should be at 1.310m centres. (1.3m plus 10mm tolerance).

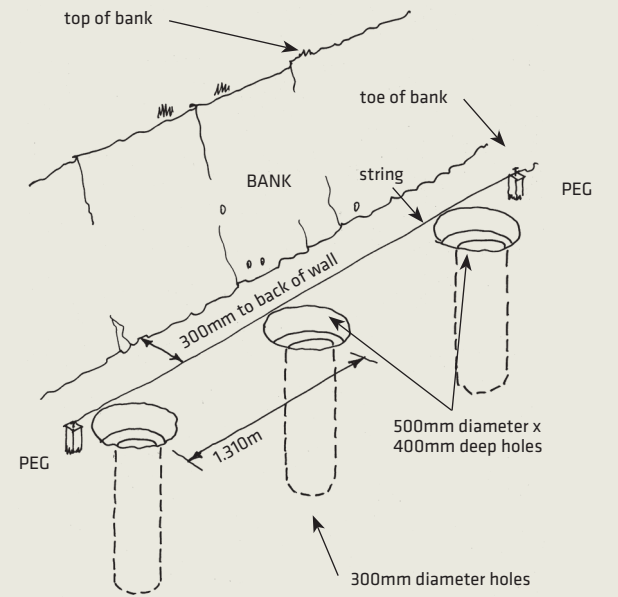

STEP 3

ENDPOSTS

Start the holes for the posts 500mm in diameter and 400mm deep. Then using a post hole borer dig 300mm diameter holes so that the total depth is 1.3m. The hole should be angled to allow the posts to slope (the slope should be 1:10 or about 120mm out from the line at the top).

Put about 100mm of stiff concrete in the two end holes and then place the two end posts in place. Make sure that the posts are vertical when viewed from the front but slope towards the bank at 1:10. Fix the posts temporarily in place with timber braces tacked with nails. With the posts held firmly in place surround the posts with stiff concrete, rodding it into place as the filling proceeds.

NOTE: A GRADIENT SLOPE OF 1:10 MEANS THAT FOR EVERY 10MM UP THE ENDPOST SLANTS 1MM BACK TOWARDS THE BACKFILL AREA.

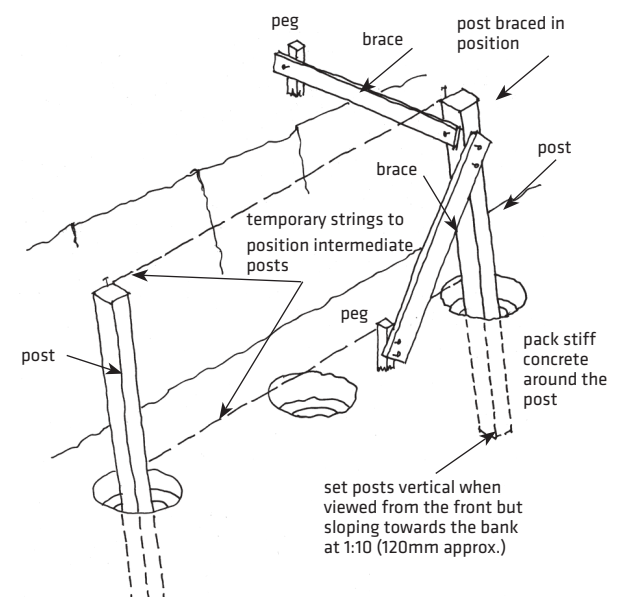

STEP 4

INTERMEDIATE POSTS

Run strings between the end posts at top and bottom and use these to line up the intermediate posts and concrete them in place as for the end posts (see step 3). Note: Place only the uncut ends of poles into holes. Paint the cut ends of poles liberally with timber preservative.

STEP 5

RAILS

Allow the concrete to harden for a minimum of two days and then nail the rails in place, making sure that they are level, using one 150mm galvanised nail at each post and starting with the bottom rail. Stagger the rails so that butt joints in rails occur alternately on each post.

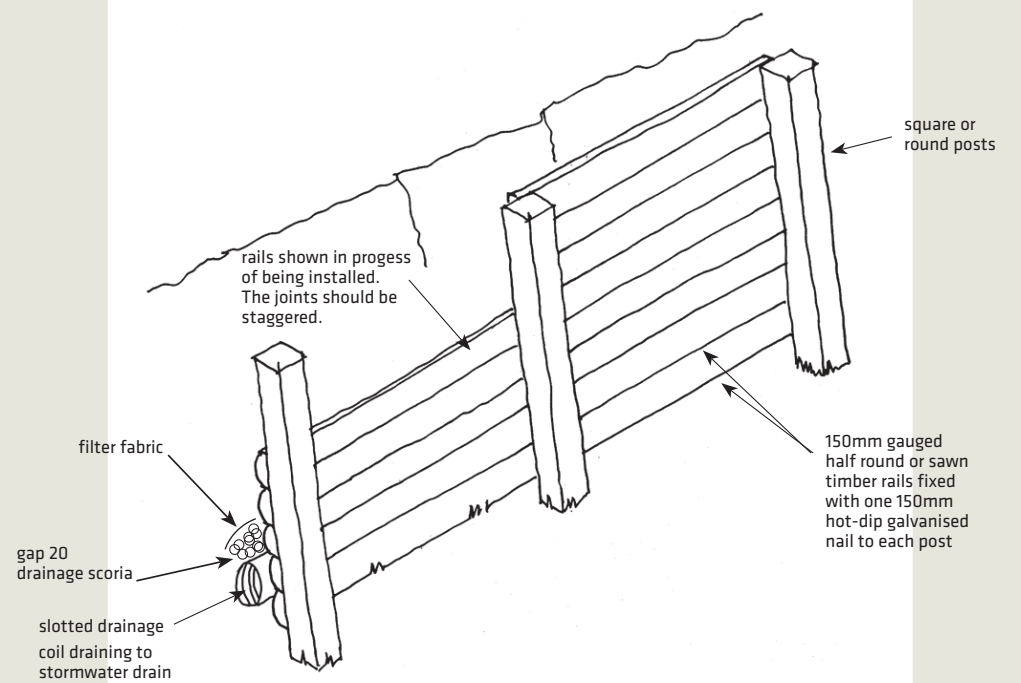

STEP 6

DRAINAGE & BACKFILL

To limit the build up of water behind the wall it is essential that drainage be provided. Lay 150mm depth of metal behind the bottom of the wall and place the draincoil on top of it and lead the ends to where they can discharge into the open (alternatively they may be connected to a suitable stormwater drain).

Cover the draincoil with 250mm of metal and lay the geotextile over it (this will reduce the silting up of the draincoil).

Continue to fill with drainage metal ensuring that there is a minimum of 300mm against the wall; the rest of the gap between the wall and the bank may be filled with well compacted excavated material. The backfill and drainage metal can be kept separate by a sheet of metal or hardboard which is slid up as the work proceeds. The top 100mm may be filled with topsoil to assist plant growth.

